

1-A

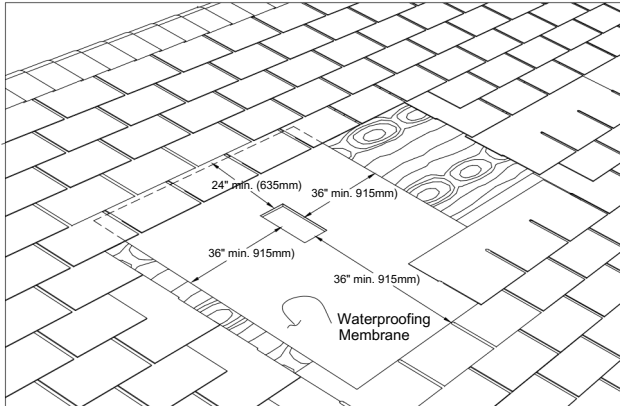

Existing Roof: Remove the shingles around the opening dedicated to the installation of the roof exhaust in order to install a waterproofing membrane around the hole as shown above.

Opening: Strategically choose the location of the roof exhaust considering winter roof snow accumulations. The roof exhaust should be located in an area where snow accumulation is minimized.

1-B

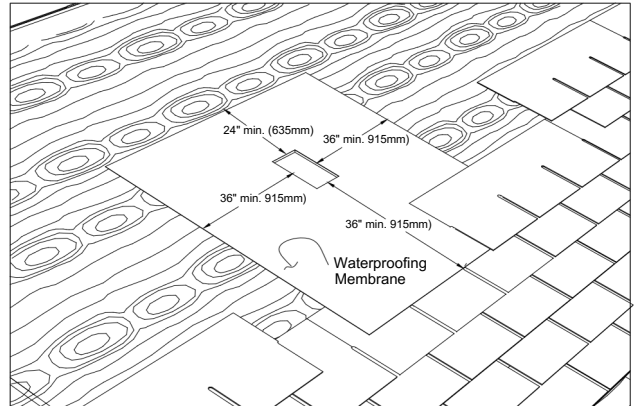

New roof: Install a waterproofing membrane around the opening dedicated to the installation of the roof exhaust as shown above.

Opening: Strategically choose the location of the roof exhaust considering winter roof snow accumulations. The roof exhaust should be located in an area where snow accumulation is minimized.

2

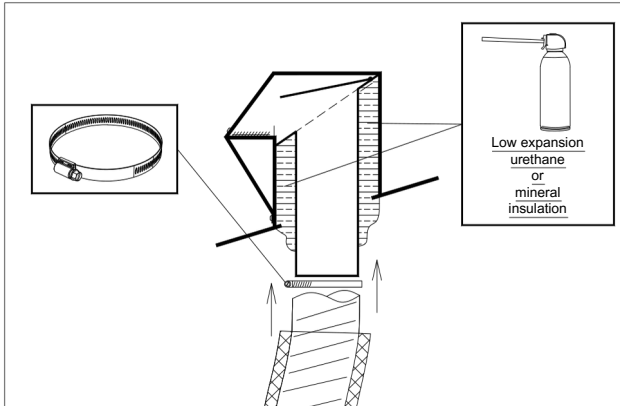

Install mineral-type insulation or low expansion urethane type insulation between the flap walls and the exhaust duct. Make sure to install insulation tightly all around the exhaust duct without leaving any empty spaces. Install an insulated flexible duct (2" insulation recommended) on the roof exhaust duct using an adjustable collar. Seal tightly with duct tape.

Note: Following the installation of the low expansion urethane type insulation, make sure damper inside the roof exhaust (model CT) is not clogged or jammed with sprayed urethane.

3

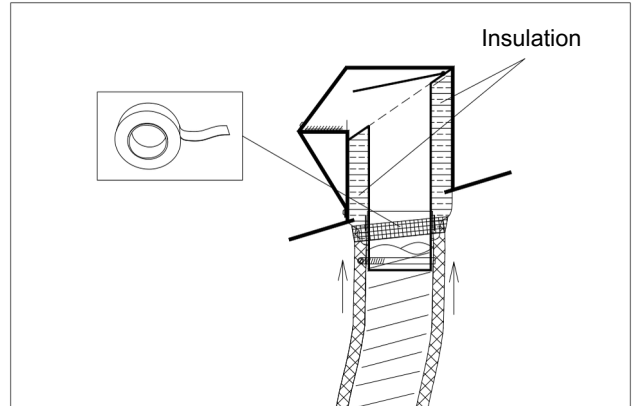

Fold the polythene (vapor barrier) over the insulation and push it to the bottom of the roof exhaust unit to ensure that the entire duct is covered. Finish by fixing it with a good quality duct tape. Ensure there are no exposed or uninsulated duct sections.

4

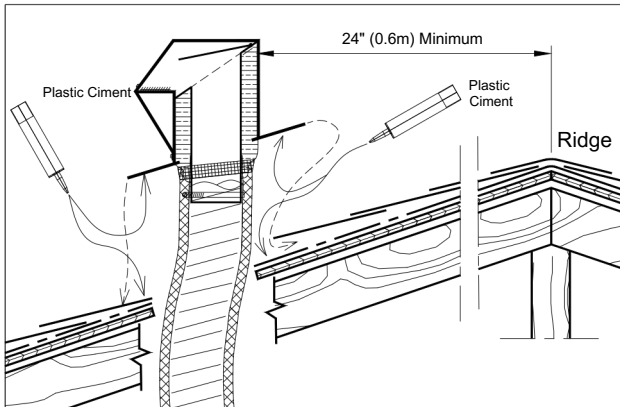

Apply plastic cement generously around the perimeter of the opening making sure to maintain a width of 4 inches. Slide the flexible duct into the opening, followed by the roof exhaust unit making sure the flashing is fully embedded in the plastic cement. Nail or screw the unit to the bridging (1 inch from the edge of the unit) while leaving a spacing of 4 inches. Finish by applying a generous amount of plastic cement to the back and sides of the flashing.

5

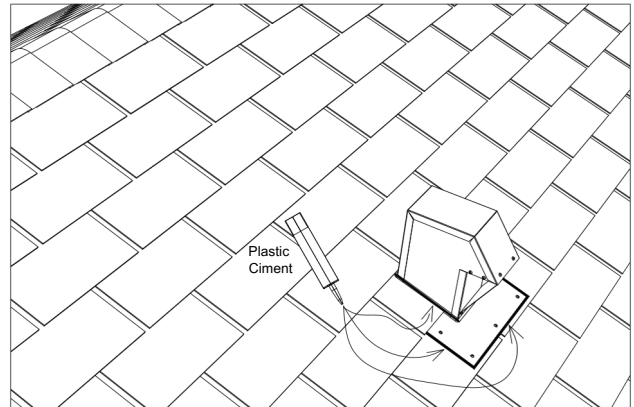

Nail the shingles in place and finish by applying a sealant around the body of the roof exhaust, flashing and shingles.

Note: If the exhaust unit is used for dryer venting, regular maintenance is required to prevent lint from blocking the roof exhaust grille.

Note: In winter, regular snow removal around the exhaust unit is required to prevent snow accumulation and ice formation.