

VENTILATION MAXIMUM

Installation for all Air Intake Vent VMAX-AT2 on steel roofs (new and existing construction)

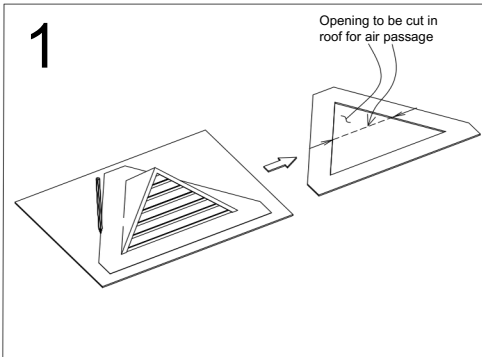

Using cardboard or other thin material, make a template of the unit following the flanges. Trace the triangular opening under the unit for the air passage and also the triangular shape of the AT2 that will be thru the existing roof.

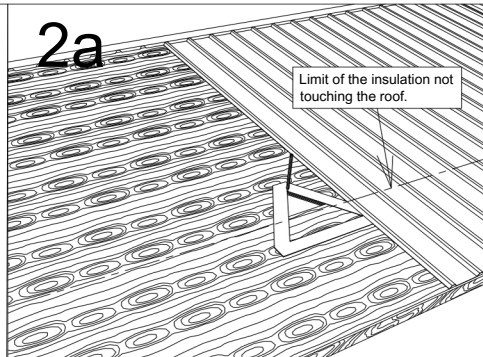

New roof: Place template onto desired location, making sure the opening is positioned between the rafters, at a few feet from the edge of the roof and over the insulation, then trace a line around the inside perimeter of the template on the top section, using a chalk and cut the top opening in the roof.

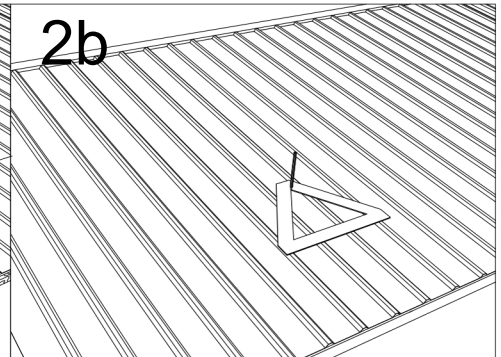

Existing roof: Place template onto desired location, making sure the hole is positioned between the rafters, then trace a line around the perimeter of the inside of the template, cut and remove the steel parts. Trace and cut the top triangular opening in the roof.

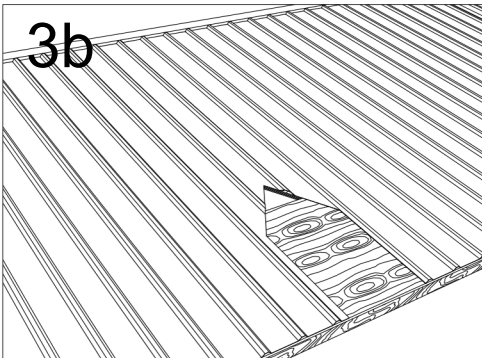

Existing roof: Remove the steel roof panels from the opening up to the edge of the roof.

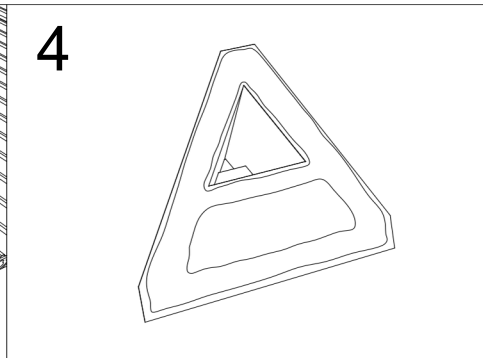

Apply a generous amount of bitumen sealant onto the underside of the flashing.

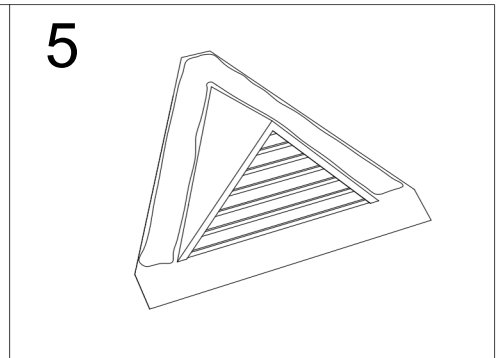

Apply a generous amount of bitumen sealant onto top of flashing as per illustration.

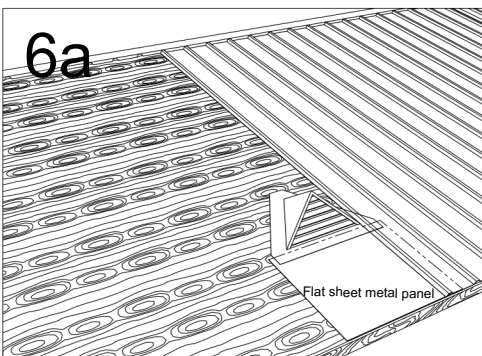

New roof: Slide the AT2 under the roof steel panels and center over the opening already cut. Place a flat sheet metal panel at the bottom and under the flashing of the AT2 up to the edge of the roof. Finish the roof installation.

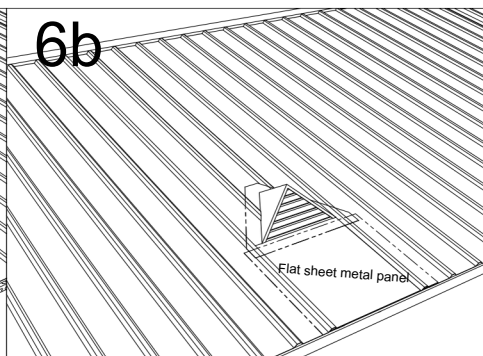

Existing roof: Slide the AT2 under the adjacent roof steel panels (2 sides) and center over the opening already cut. Place a flat sheet metal panel at the bottom and under the flashing of the AT2 up to the edge of the roof.

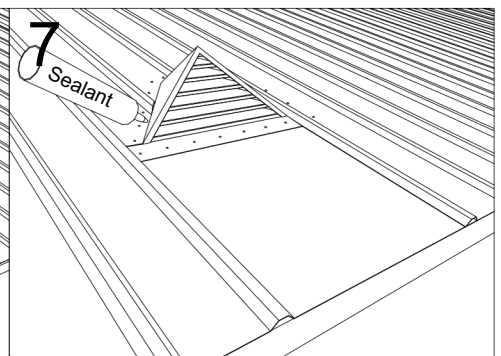

Secure bottom flange using galvanized roofing screws with rubber rings on the 3 sides of the AT2 (supplied by contractor). Finish by installing a bead of sealant around perimeter of unit, sealing all joints.