

Using cardboard or other thin material, make a template of the underside of the unit including the opening.

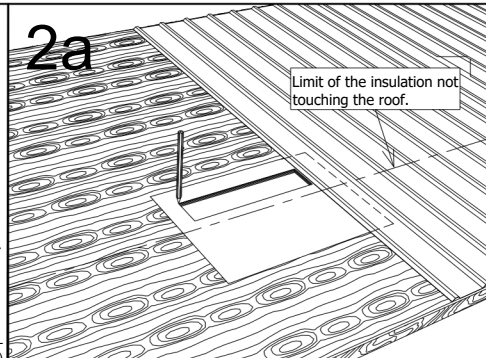

New roof: Place template, making sure the opening is positioned between the rafters, at a few feet from the edge of the roof and over the insulation. Trace and cut an opening in the center of the template.

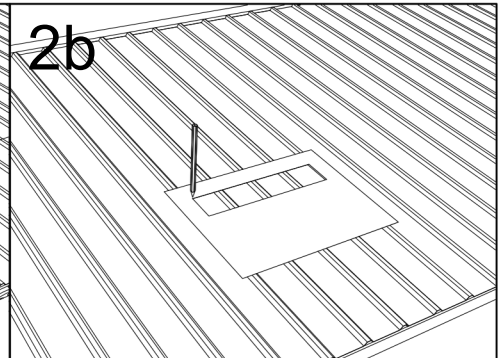

Existing roof: Place template, making sure the opening is positioned between the rafters, at a few feet from the edge of the roof and over the insulation. Trace and cut an opening in the center of the template.

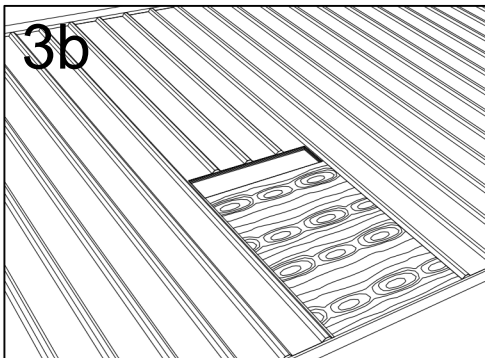

Existing roof: Remove the steel roof panels from the opening up to the edge of the roof.

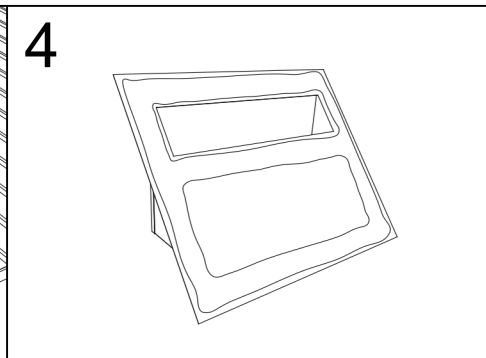

Apply a generous amount of bitumen sealant onto the underside of the flashing.

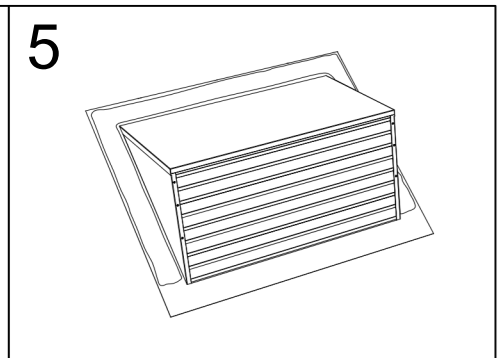

Apply a generous amount of bitumen sealant onto top of flashing as per illustration.

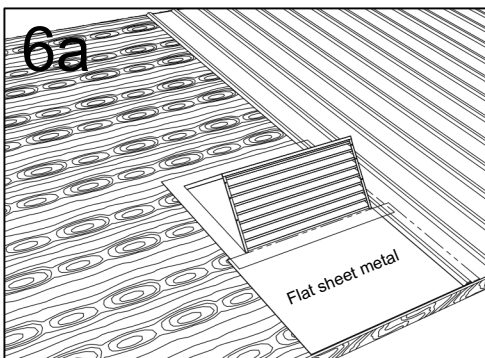

New roof: Slide the AT1 under the roof steel panels and center over the opening already cut. Place a flat sheet metal panel at the bottom and under the flashing of the AT1 up to the edge of the roof. Finish the roof installation.

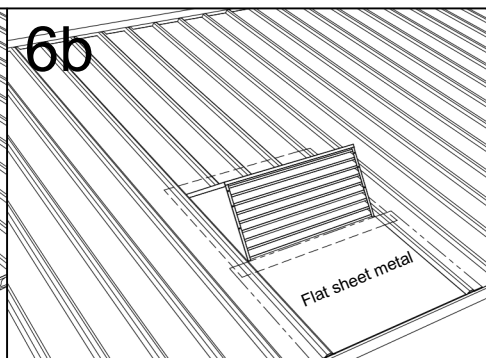

Existing roof: Slide the AT1 under the adjacent roof steel panels (3 sides) and center over the opening already cut. Place a flat sheet metal panel at the bottom and under the flashing of the AT1 up to the edge of the roof.

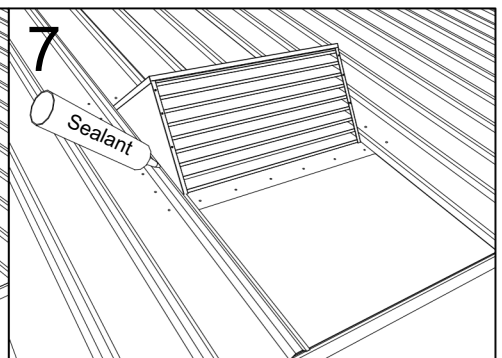

Secure bottom flange using galvanized roofing screws with rubber rings on the 4 sides of the AT1 (supplied by contractor). Finish by installing a bead of sealant around perimeter of unit, sealing all joints.